

Technical description

General	200-1	Full-load operation (Pierburg)	200-15
Single carburettor (Stromberg)	200-1	Engine overrun	200-15
Twin carburettors	200-3	Idling shut-off valve	200-17
Single carburettor (Pierburg)	200-3	Air cleaner	200-20
Float system	200-6	Preheating	200-20
Cold-start device	200-8	Fuel pump	200-21
Fast idling	200-11	Fuel tank	200-22
Idling (Stromberg)	200-11	Fuel tank venting and overflow protection	200-22
Acceleration (Stromberg)	200-12	Fuel supply and fuel return line	200-22
Normal driving (Stromberg)	200-12	Roll-over valve	200-24
Idling (Pierburg)	200-13		
Acceleration (Pierburg)	200-14		
Normal driving (Pierburg)	200-14		

General

The engine is equipped with one or two Stromberg horizontal carburettors.

As from 1987 models, the engine is equipped with a Pierburg carburettor.

Single carburettor (Stromberg)

The carburettor, made of light alloy metal, comprises three main sections: the vacuum chamber, the carburettor body (casting) and the float chamber.

The vacuum chamber, which is the top part of the carburettor, has a diaphragm at the bottom, to which a piston is attached, and communicates with the inlet port of the carburettor through two drillings in the piston.

The fuel jet is press-fitted in the carburettor body, which is the middle section of the carburettor. The cross-sectional area of fuel flow inside the jet orifice is varied by a moving tapered needle, attached to a piston whose position is varied by variations in the depression inside the carburettor body. The piston also regulates the cross-sectional area of the flow of induction air. Thus, the engine always receives the correct amount of fuel and air under all load conditions.

The bottom section of the carburettor, the float chamber, houses a float which opens and closes the float valve by means of a tab on the float arm.



Twin carburettors

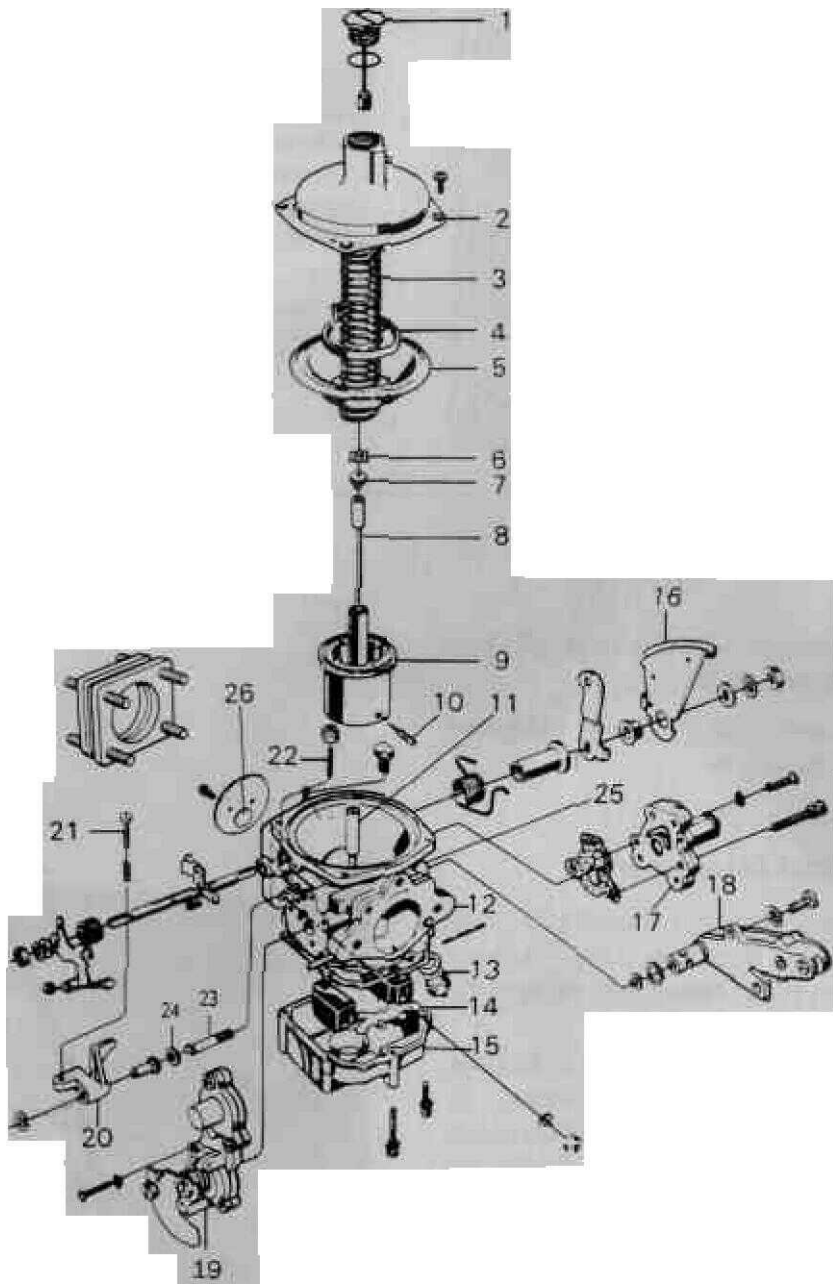

Carburettor (Stromberg)

- | | |
|--|---|
| 1 Damper and oil cap assembly | 14 Float and arm |
| 2 Vacuum chamber cover | 15 Float chamber |
| 3 Spring | 16 Throttle cam lever |
| 4 Retaining ring for diaphragm | 17 Deceleration valve (not Sweden spec.) |
| 5 Diaphragm | 18 Temperature compensator |
| 6 Retaining clip | 19 Cold start device with cam lever |
| 7 Adjusting screw | 20 Arm, float chamber ventilation |
| 8 Metering needle | 21 Idling adjusting screw |
| 9 Vacuum piston | 22 Adjusting screw, float chamber ventilation |
| 10 Setscrew with spring loaded plunger | 23 Spindle |
| 11 Jet | 24 Spacer (single carburettors only) |
| 12 Carburettor body | 25 CO adjusting screw |
| 13 Float valve | 26 Deceleration valve (1985 models onwards) |

Twin carburettors

The carburettors used on twin-carburettor engines are similar in principle to those on single-carburettor engines.

Located in front of the two carburettors is an air box, which serves both carburettors and is connected to the air cleaner by means of a hose. The inlet manifold passages from the rear carburettor go to number 1 and 2 cylinders and from the front carburettor to cylinders number 3 and 4. A connecting passage links the two manifolds and this serves to correct any minor variations in the fuel/air mixture from the two carburettors.

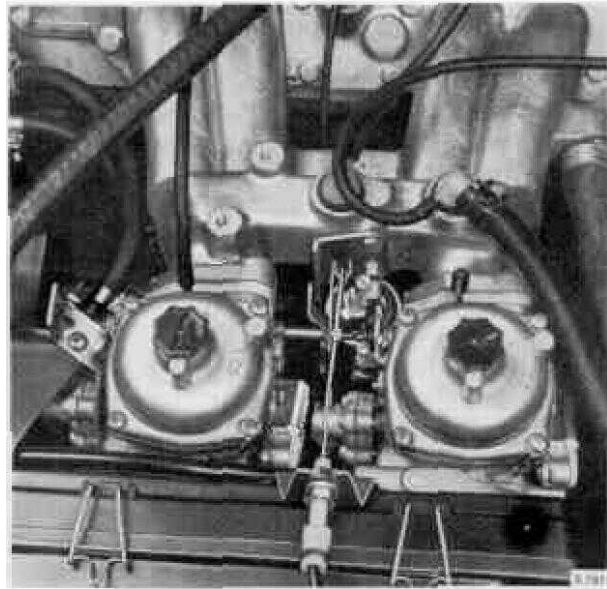

Twin carburetors

Pierburg 175 CDUS carburettor

The 175 CDUS carburettor is a horizontal, constant-depression (CD) carburettor with a mixing chamber diameter of 45 mm (1 $\frac{3}{4}$ ").

In a constant-depression (CD) carburettor, the vacuum in the mixing chamber does not vary, i.e. the pressure of the air stream is practically constant, regardless of the engine speed or **load**.

The piston and thus the jet are controlled by a vacuum, which varies with the throttle opening, the engine speed and the engine load. The interaction of these factors and the atomization of the fuel (due to the nearly constant vacuum resulting from a constant air speed at the jet) comprise the basic principle of a constant-depression (CD) carburettor. The combination of a variable jet system and an air-controlled vacuum piston provides step-less adjustment of the fuel/air mixture supplied to the engine, from idling to full load.

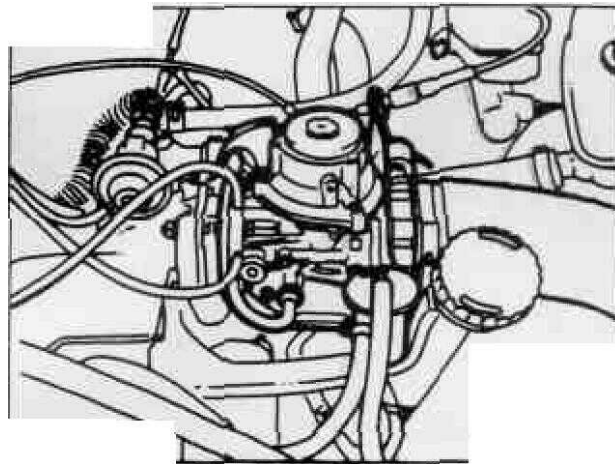

As from 1987 models, the engine is equipped with a Pierburg carburettor.

Because of the central location of the jet system, the carburettor can be installed horizontally, or inclined at the angle of up to 26°.

The fuel supply to the jet is regulated by the double float, and is kept at a constant level, so that centrifugal, braking and acceleration forces will not affect the fuel/air mixture.

The CDUS carburettor is equipped with a choke disc controlled by a manual choke control, a deceleration valve (overrun braking valve), which reduces exhaust emissions during overrun braking and gear-changing and a device which allows the idling mixture to bypass the throttle.

At idling speed, the mixture bypasses the almost closed throttle, via the idling shut-off valve, and flows direct to the inlet manifold. This provides a higher effective vacuum for delivery of the mixture and thus guarantees smooth idling.

Another feature of this carburettor is the temperature compensation function of the main jet. The jet holder contains **bimetal** washers, which move the jet axially when the temperature changes. This, in turn, changes the flow area of the jet. The fuel flow is thus adjusted to suit the prevailing operating temperature.

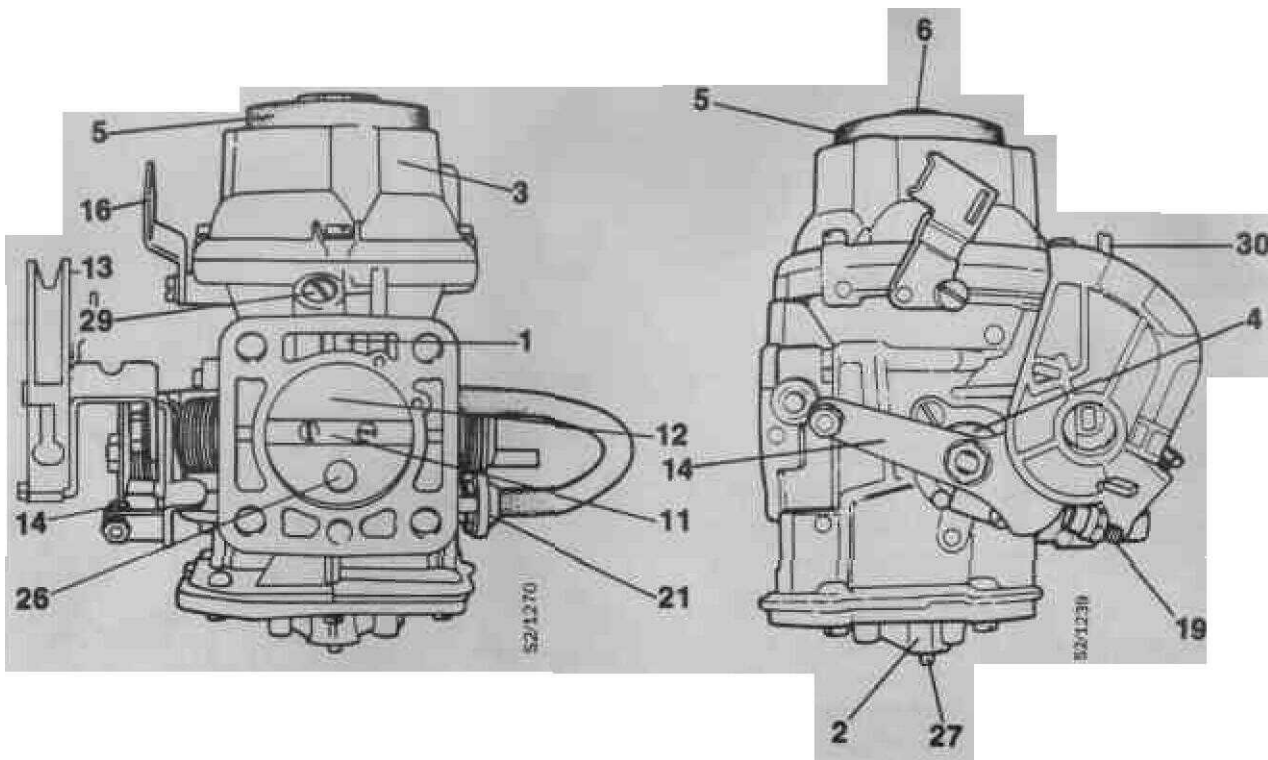

- | | |
|-------------------------|--|
| 1 Carburettor body | 13 Throttle lever |
| 2 Float chamber cover | 14 Choke lever |
| 3 Carburettor top cover | 16 Choke cable guide |
| 4 Choke disc | 26 Deceleration valve |
| 5 Cover | 27 CO adjusting screw |
| 6 Oil filler plug | 29 Plug (connection for idling speed adjustment valve for cars equipped with AC) |
| 11 Throttle spindle | 30 Spigot for vacuum line to distributor |
| 12 Throttle butterfly | |

Carburettor design

The carburettor consists of four main parts, held together by screws:

- Carburettor body
- Float chamber cover
- Carburettor top cover
- Choke mechanism

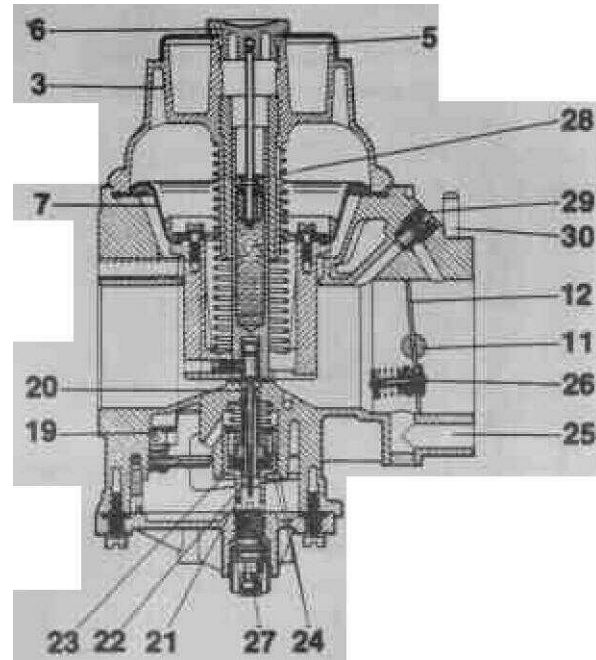
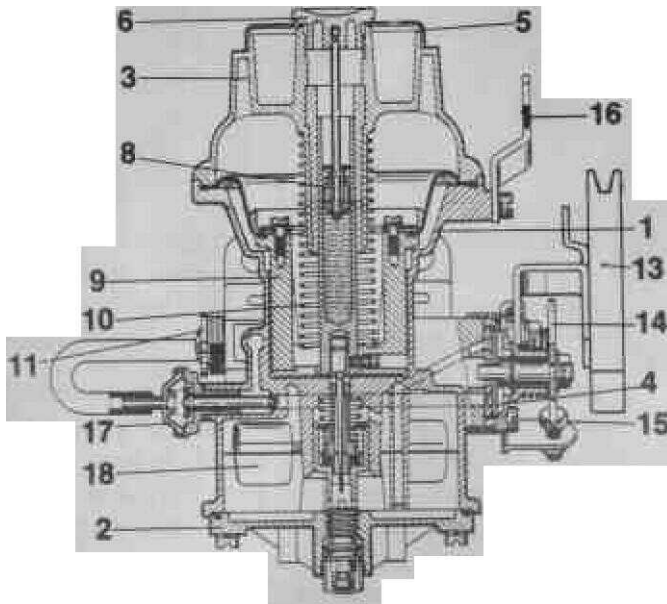

- | | |
|--------------------------------------|--|
| 1 Carburettor body | 17 Modulator valve (lean-mixture valve) |
| 2 Float chamber cover | 18 Float |
| 3 Carburettor top cover | 19 Float valve |
| 4 Choke disc | 20 Jet |
| 5 Cover | 21 Jet holder |
| 6 Damper piston and oil cap assembly | 22 Needle |
| 7 Piston diaphragm | 23 Bimetal washers |
| 8 Damper piston | 24 Springs |
| 9 Vacuum piston | 25 Idling by-pass passage |
| 10 Vacuum piston spring | 26 Deceleration valve |
| 11 Throttle spindle | 27 CO adjusting screw |
| 12 Throttle butterfly | 28 Damper oil |
| 13 Throttle lever | 29 Plug (connection for idling speed adjustment valve for cars equipped with AC) |
| 14 Choke lever | 30 Spigot for vacuum line to distributor |
| 15 Fast idling adjusting screw | |
| 16 Choke cable guide | |

Auxiliary devices

Shut-off valve for idling mixture

The induction system incorporates a shut-off valve for the idling mixture to prevent the engine running on after the Ignition has been switched off. The valve, a solenoid valve, fitted in the underside of the inlet manifold, opens when the ignition is switched on.

Idling control valve

On cars with AC, the carburettor is equipped with an idling control valve instead of plug 29. This valve opens when the AC compressor cuts in, thereby enriching the mixture and preventing a decrease in the engine speed.

Float system

Stromberg

Fuel enters the float chamber through the float valve. The float, which is double, is mounted on the float chamber by an arm and spindle, which fits into two retaining clips. As the fuel level rises, the float rises with it, and when the correct level is reached, the float valve is closed by a tongue on the float arm. Fuel is also drawn into the jet, where the level will be the same as in the float chamber (engine at standstill).

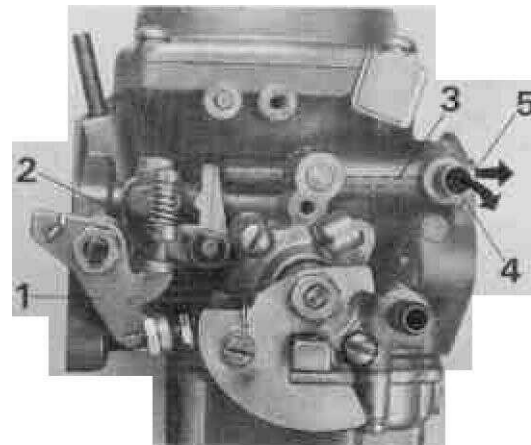

Float chamber ventilation, twin carburettors

- 1 Throttle stop and fast idle lever
- 2 Throttle relay lever and idle adjust screw
- 3 Ventilation valve
- 4 Ventilation outlet, throttle shut
- 5 Ventilation outlet, throttle open

The carburetors are fitted with a special float chamber vent valve. When the throttle valve is closed, air is expelled directly through a vent hole in the carburetor. When the throttle valve is opened, ventilation of the float chamber will be by means of the air cleaner connection.

Pierburg

The float system controls the fuel flow by means of the float, which operates the float valve via the float arm, thereby keeping the fuel level in the float chamber constant under all conditions.

The fuel supplied by the fuel pump flows through the supply tube and the open float valve in the float chamber. As the fuel level rises, the float also rises, pressing the float valve needle against its seat. When the preset fuel level has been reached, the float valve closes and will not reopen until the fuel level in the float chamber **has again** fallen.

When the engine is running, the float chamber is vented via the valve in the chamber to the air filter (internal venting).

With the engine at a standstill, venting is via the valve in the float chamber to the engine compartment (external venting).

The valve is located in the air inlet flange

When the engine is running, this valve is closed, and the internal vent passage open. When the ignition is switched off and the engine has stopped, the electrical supply to the valve is cut off, causing the passage for internal venting to close and the passage for external venting to open.

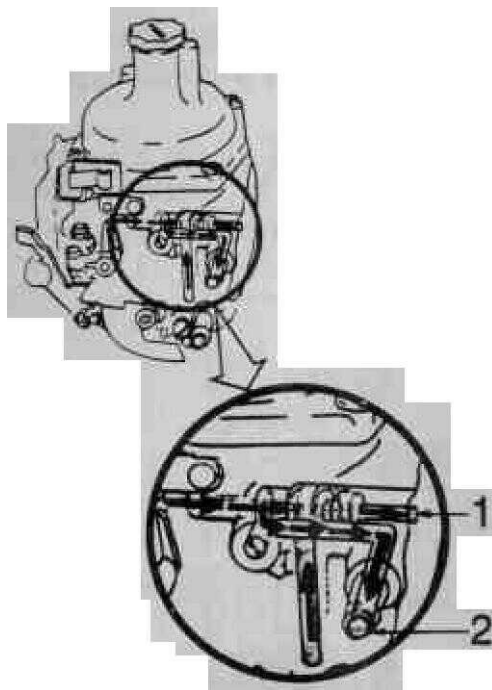

Float chamber ventilation

- 1 Ventilation through air cleaner
- 2 Direct atmospheric ventilation

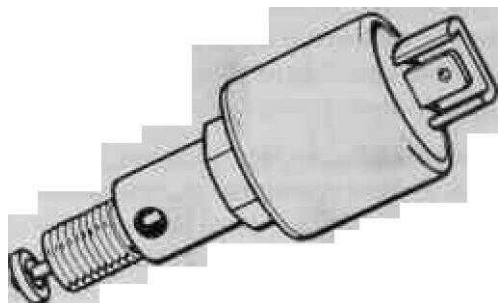

Float chamber vent valve

Cold-start device (choke)

The carburettor is equipped with a cold-start device to assist starting and running the engine from cold.

As the engine warms up, the choke control is pushed in to maintain the correct fuel/air mixture as the fast-idling speed decreases.

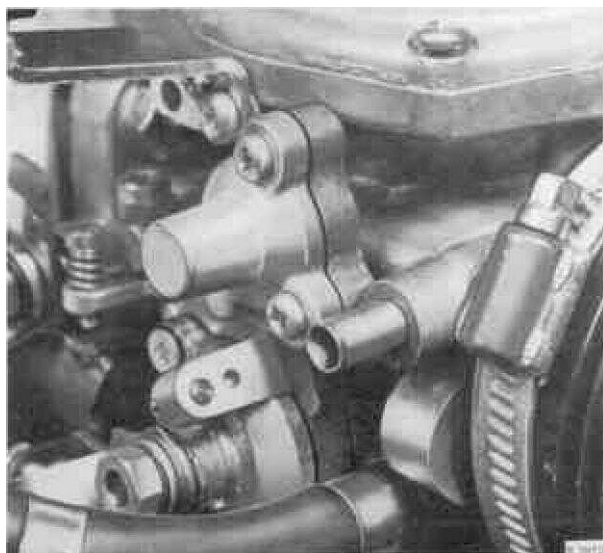

Cold-start device (Stromberg)

Stromberg

When the choke control is pulled out, a disc (4) is rotated and fuel flows from the float chamber through one, two, three or four of the holes in the disc. The fuel flow through the disc is determined by the number of the holes that are not blanked off. Additional air to the disc is drawn in through air jet (3), to form an emulsion with the fuel. The additional fuel/air mixture then flows into the mixing chamber through passage (6a).

(Refer to Fig. A.)

To enable the engine to run smoothly under all driving conditions, the quantity of choke fuel is optimized to meet the requirement during acceleration or at full throttle (Fig. A). This quantity of fuel is much greater than that needed when the car is travelling at a constant speed.

A leaner mixture is obtained as follows (Fig. B).

At constant speed (constant throttle opening), a depression is present in the inlet manifold. Via connecting passage (8) the depression acts on the diaphragm (1), once the force of the spring (2) has been overcome, allowing air to be drawn through passage (9) into the fuel inlet passage (5). The fuel/air mixture flows through the disc (4), where additional air is drawn in through air jet (3). This lean mixture (6b) then flows into the mixing chamber, providing additional fuel/air.

On renewed acceleration (opening of the throttle), the mixture is automatically enriched (load-sensing choke), since there is a reduction in the depression in the inlet manifold, which allows the spring loading on the diaphragm to close the air-bleed port.



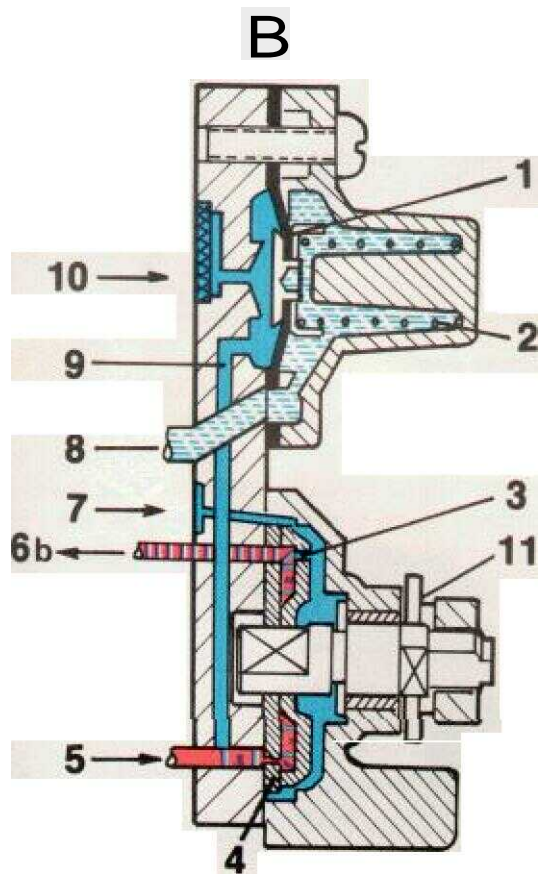

Operating principle of the cold-start device (Stromberg)

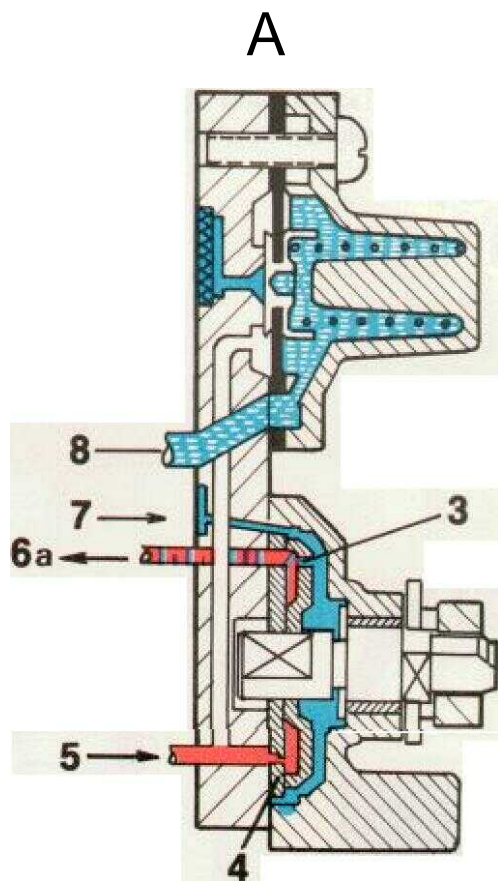

At constant speed



On starting, during acceleration and at full throttle

	= Fuel
	= Air (at atmospheric pressure)
	= Strong depression
	= Weak depression
	= Fuel/air mixture

- | | |
|---|---|
| 1 Diaphragm | 7 Air inlet from atmosphere (as from 1984 models) |
| 2 Diaphragm spring | 8 Passage to inlet manifold |
| 3 Air jet | 9 Air-bleed passage |
| 4 Disc | 10 Air-bleed passage inlet from atmosphere |
| 5 Fuel inlet passage (from float chamber) | 11 Fast-idling cam |
| 6 a Fuel/air passage (rich mixture to mixing chamber) | |
| 6 b Fuel/air passage (lean mixture to mixing chamber) | |

Pierburg

The choke disc, which is controlled by the choke control, permits reliable starting and warm-up of the engine, regardless of the ambient temperature. When a car is started from cold, a rich fuel/air mixture is required at first. When the choke control is withdrawn, the throttle (12) is partially opened (fast idling) and the choke disc (4) is turned to a position in which the fuel apertures are opened.

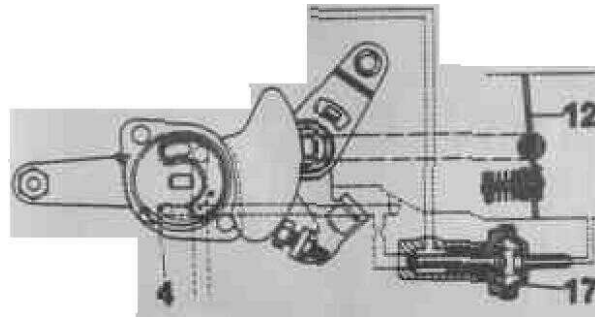

- 4 Choke disc
- 12 Throttle butterfly
- 17 Modulator (lean-mixture) valve

During starting, fuel is metered from the float chamber (A) via the fuel apertures in the choke disc (4).

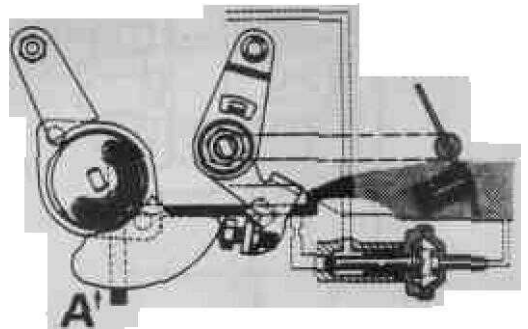

Cold starting

A Fuel supply from float chamber

Immediately after the engine has started, the modulator valve (lean-mixture valve) (17) opens in the inlet manifold. Thus, the air required for a leaner mixture flows through a passage (B), from the clean-air side of the air cleaner.

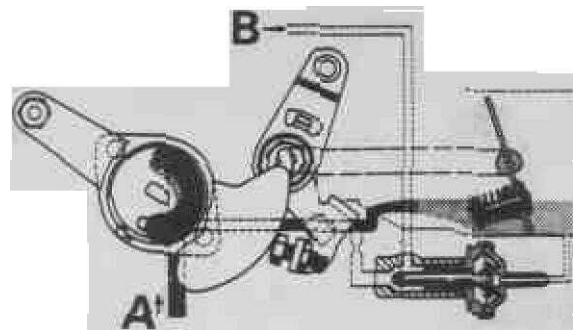

Warm starting

B Air supply

Fast idling

When the choke control is pulled out, a cam, which acts on the throttle, is rotated. The further the choke control is withdrawn, the faster will be the fast idling speed.

Idling (Stromberg)

The carburettor does not have a separate idling system. At idling speed there is a depression in the vacuum chamber. In this position the thickest section of the tapered metering needle is in the jet orifice and only a small quantity of fuel, sufficient for idling, is inducted into the cylinders. The air/fuel mixture should be set while the engine is idling by adjusting the relationship between the metering needle and the jet aperture. This is effected by altering the orifice adjusting screw which raises or lowers the tapered metering needle and it is this setting which then covers the entire range of engine speeds. The idling speed is changed by adjusting the setting of the throttle stop screw (idle-adjust screw). On twin-carburettor engines the throttles can be synchronized by adjusting the clamping bolt on the coupling assembly between the two throttle spindles. The carburettor is equipped with a temperature compensator to maintain a constant fuel/air mixture regardless of engine temperature. The temperature compensator consists of an atmospheric valve controlled by a bi-metallic strip. The valve starts to open when the temperature of the air at the temperature compensator reaches 68°F (20°C) approx. Additional air is introduced through a vent which discharges behind the air valve shaft.

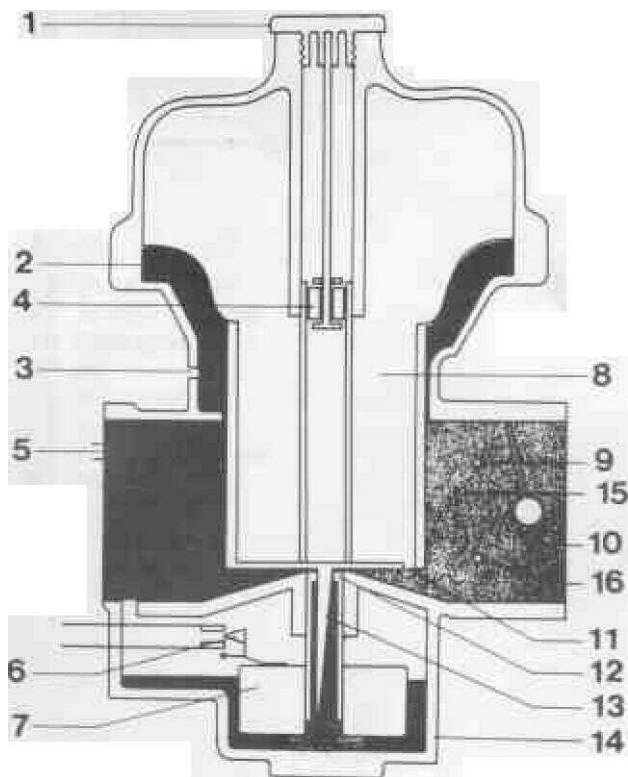

Carburettor with throttle closed (Stromberg)

- 1 Damper piston and oil cap assembly
- 2 Diaphragm
- 3 Compensating aperture
- 4 Damper piston
- 5 Float chamber vent.
- 6 Float valve
- 7 Float
- 8 Vacuum piston
- 9 Starting-fuel aperture
- 10 Throttle butterfly
- 11 Vacuum aperture
- 12 Needle
- 13 Jet orifice
- 14 Float chamber
- 15 Constant-depression chamber (CD chamber)
- 16 Aperture for additional air (temperature compensation)

Acceleration (Stromberg)

A damper piston is provided in the centre of the air valve in order to provide a richer mixture when the throttle is opened rapidly (acceleration). The damper consists of a piston, which runs in oil, attached to a rod. When the throttle is opened quickly the depression in the vacuum chamber increases rapidly. When the air valve rises the piston damper is forced against its seat preventing the oil from flowing past which retards the movement of the air valve. This causes a temporary increase in the depression above the jet orifice and the air/fuel mixture is enriched. The downward movement of the air valve is spring-assisted.

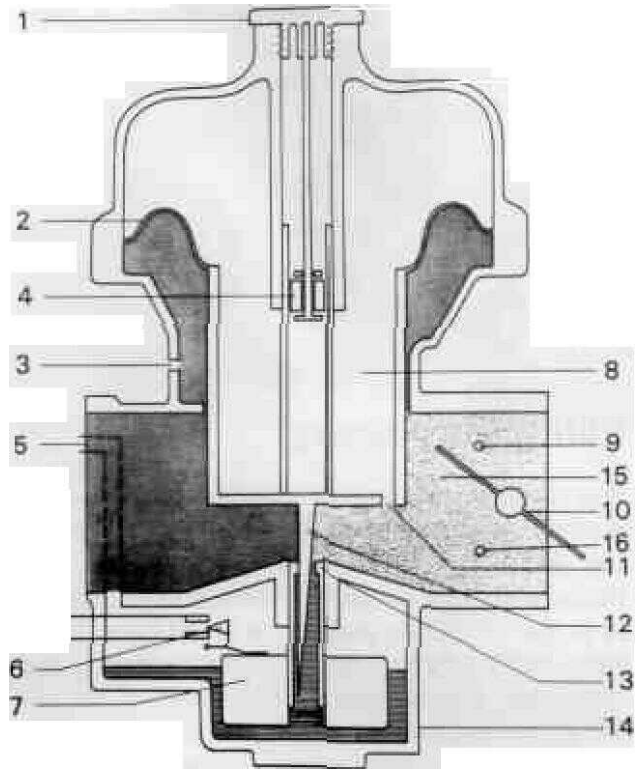

Carburettor with throttle open (Stromberg)

- 1 Damper piston and oil cap assembly
- 2 Diaphragm
- 3 Compensating aperture
- 4 Damper piston
- 5 Float chamber vent.
- 6 Valve
- 7 Float
- 8 Vacuum piston
- 9 Starting-fuel aperture
- 10 Throttle butterfly
- 11 Vacuum aperture
- 12 Jet orifice
- 13 Needle
- 14 Float chamber
- 15 Constant-depression chamber (CD chamber)
- 16 Aperture for additional air (temperature compensation)

Normal driving (Stromberg)

When the throttle is opened, the pressure in the vacuum chamber, which is in communication with the top of the diaphragm, falls, causing the piston to rise to a new position, stabilizing the depression in the vacuum chamber. As the needle rises with the piston, the flow of fuel is adjusted to the flow of air.

Idling (Pierburg)

This carburettor is not equipped with a separate idling system. Instead, the idling mixture depends on the position of the throttle butterfly (12), the vacuum piston (9) and the taper needle (22) in the jet, which controls the fuel flow.

Turning the adjusting screw (27), which is in contact with the jet holder (21), alters the position of the jet (20), thus also changing the annular gap between the jet and the needle.

When the adjusting screw is turned clockwise, the annular gap is reduced, thus providing a leaner idling mixture. Turning the screw anti-clockwise has the opposite effect.

When the engine is running, the resulting vacuum causes fuel to be drawn into the mixing chamber, where it is mixed with the air flowing past the top of the jet.

The carburettor is equipped with a by-pass device for the idling mixture. Most of the idling mixture flows from the mixing chamber, past the ~~throttle which is set to a minimum opening and~~ into the inlet manifold. The rest of the idling mixture flows through the throttle gap, into the engine.

The ~~bimetal~~ washers (23), located below the jet, contract when the temperature of the fuel and the surrounding metal is low.

As the temperature increases, the ~~bimetal~~ washers expand axially in the jet holder, causing the annular gap between the jet and the taper needle to decrease. This results in a leaner mixture at higher temperatures and a richer mixture at lower temperatures.

This temperature compensation helps to ensure that the optimum fuel/air ratio will be maintained, regardless of the viscosity of the fuel.

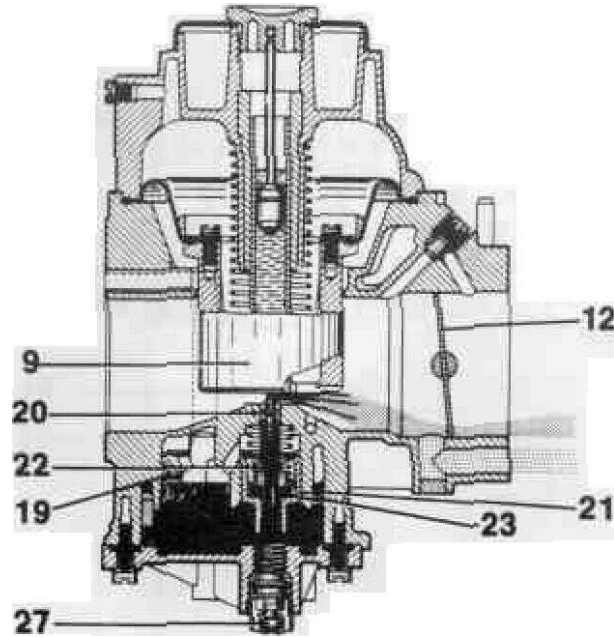

Idling

- 9 Vacuum piston
- 12 Throttle butterfly
- 19 Float valve
- 20 Jet
- 21 Jet holder
- 22 Needle
- 23 Bimetal washers
- 27 Adjusting screw

Acceleration (Pierburg)

When the accelerator is suddenly depressed, a richer fuel/air mixture is required briefly. This temporary enrichment of the mixture is achieved by means of vacuum piston spring (10) and damper piston (8) in the damper oil (28).

When the throttle is suddenly opened, the damper piston prevents an immediate upward movement of the vacuum piston (9). The vacuum of the jet (20) briefly increases, thus enriching the fuel mixture.

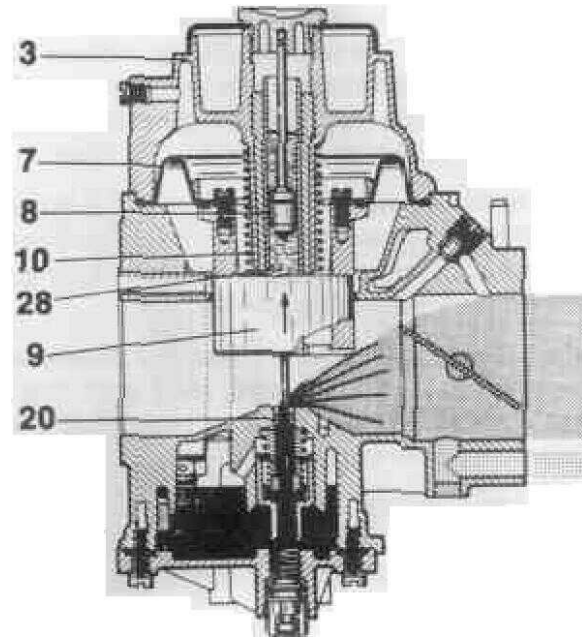

Acceleration

- 3 Carburettor cover
- 7 Diaphragm
- 8 Damper piston
- 9 Vacuum piston
- 10 Vacuum piston spring
- 20 Jet
- 28 Damper oil

Normal driving (Pierburg)

When the throttle is opened the vacuum acts on a chamber in the carburettor cover (3), through the compensating passages in the bottom of the vacuum piston, and thus also on the diaphragm (7) on the vacuum piston (9). Due to the difference between the vacuum in the chamber and the atmospheric pressure on the underside of the diaphragm, the piston is raised by an amount proportional to the air flowing past the throttle, and the cross-sectional area of the intake is increased. The air velocity and the vacuum at the jet (20) thus remain practically constant, and provide reliable atomization of the fuel at all engine speeds.

Full-load operation (Pierburg)

The more air drawn through the carburettor, the higher position of the vacuum piston (9) and the needle (22). The piston reaches its highest position at full load and maximum engine speed and the proportional increase of the annular gap at the jet (20) matches the fuel supply to the amount of air being drawn in. The shape of the needle ensures that the fuel/air ration is steplessly adjusted to the correct value under all operating conditions.

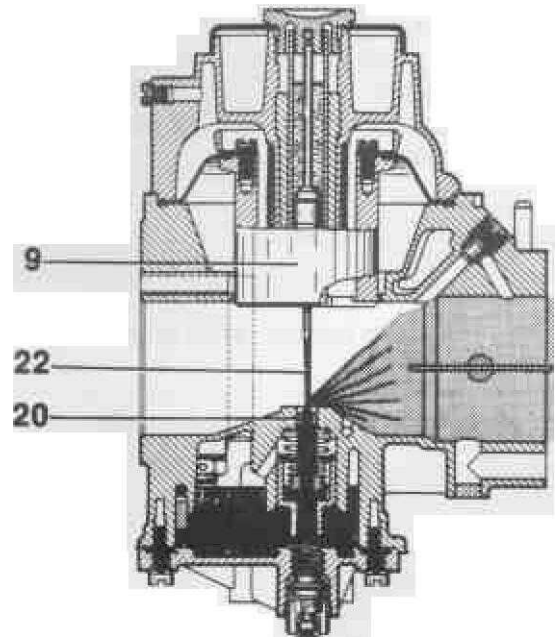

Full-load operation

- 9 Vacuum piston
- 20 Jet
- 22 Needle

Engine overrun

Sweden specification

A mechanical dashpot delays the closure of the throttle when the accelerator is released.



Sweden specification 1984 and earlier models

Europe specification (1984 and earlier models)

The carburettor is equipped with a diaphragm valve which is affected by the manifold depression during overrun, thereby opening the throttle by-pass and permitting the correct air/fuel mixture to reach the engine.

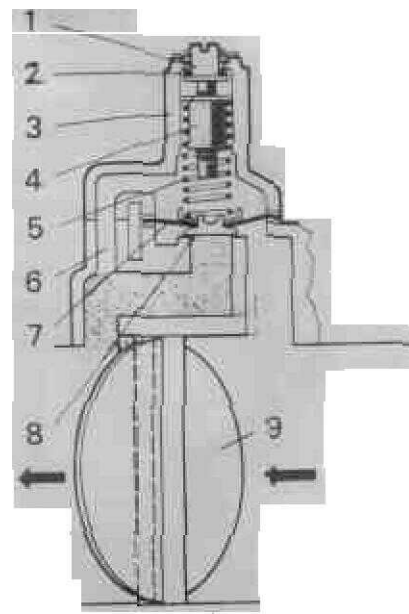

Deceleration valve, normal driving

- 1 Adjusting screw
- 2 Rubber ring
- 3 Cover
- 4 Nut
- 5 Spring
- 6 Passage to diaphragm upper side

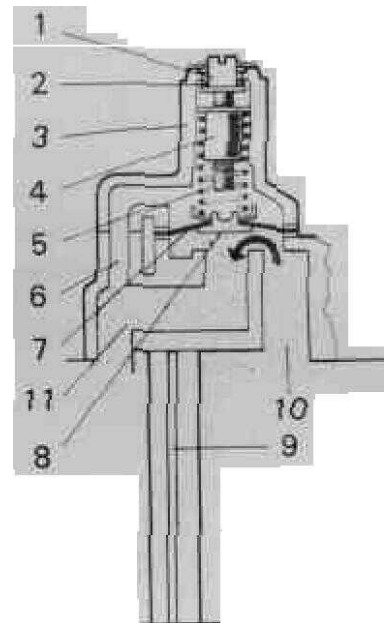

Deceleration valve, engine overrun

- 7 Diaphragm
- 8 Valve
- 9 Throttle
- 10 Air/fuel mixture inlet passage
- 11 Air/fuel mixture outlet passage

1985 models onwards

A poppet valve is incorporated in the throttle butterfly. On engine overrun, the valve opens a port in the butterfly, allowing the correct mixture of fuel and air to be admitted to the engine.

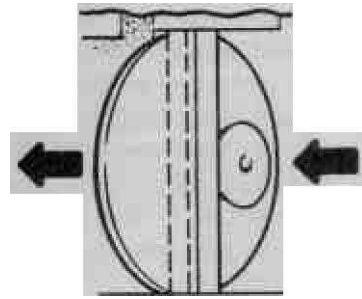

Deceleration valve, normal driving

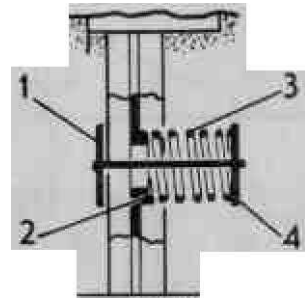

Deceleration valve, engine overrun

- 1 Poppet valve
- 2 Spring seat
- 3 Spring
- 4 Spring seat

Idling shut-off valve

Carburettor engines are equipped with an idling shut-off valve to eliminate the engine running on after the ignition has been switched off.

Single carburettor engines obtain their air/fuel mixture at idling speed through a small aperture in the throttle butterfly and through a throttle by-pass passage. When the ignition is turned off the by-pass passage is blocked by a spring-loaded solenoid which is then deprived of its electric current. The air/fuel mixture can now only pass through the aperture in the throttle butterfly, which is insufficient to keep the engine running, which therefore stops.

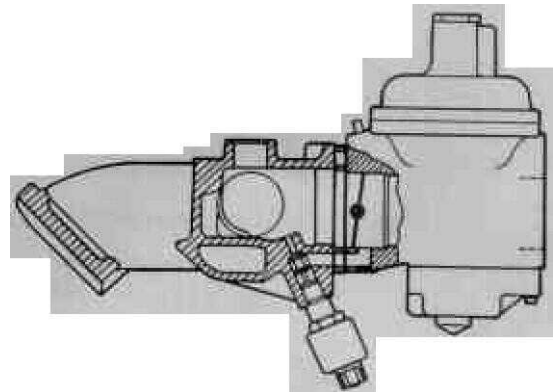
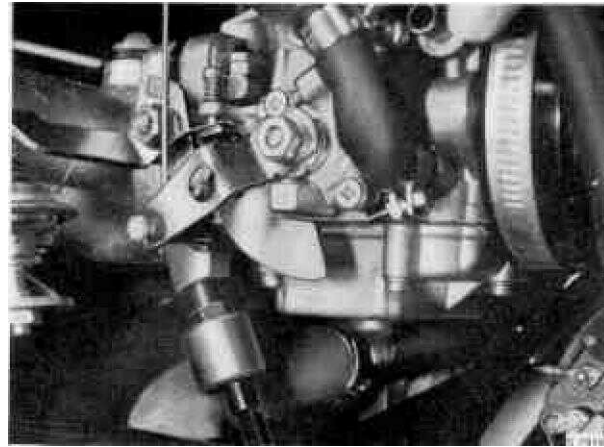

Idling shut-off valve, single carburettor

Twin carburettor engines incorporate a solenoid valve which regulates communication between the section of the float chamber above the fuel level and the constant-depression (CD) chamber. When the ignition is switched off, a time relay closes a circuit which causes the solenoid valve to open the connection to the float chamber, giving rise to a depression above the fuel level. This eliminates the pressure difference, needed for fuel to be drawn through the needle valve, and the engine therefore stops. Current to the solenoid flows for a limited time only; after six seconds, therefore, with the engine-idle, the relay will be de-energized.

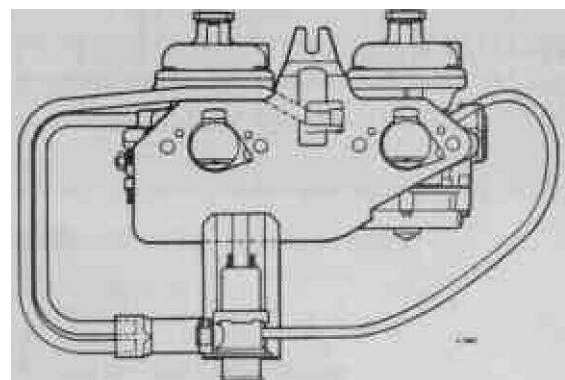
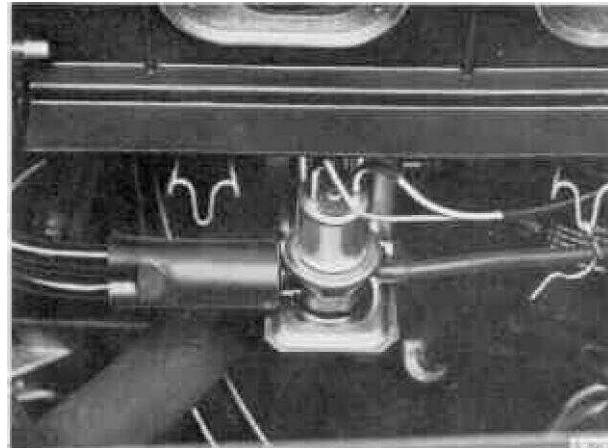

Idling shut-off valve, twin-carburettors

Stromberg carburetors (as from 1984 models)

Preheated air for cold-start device (choke)

As from 1984 models, the induction air for the cold-start device is preheated. The preheated air enters the air intake hose to the carburettor and flows through a hose to the cold-start device.

When the air is preheated, condensation is reduced, with a consequent reduction in the risk of moisture freezing in the system.

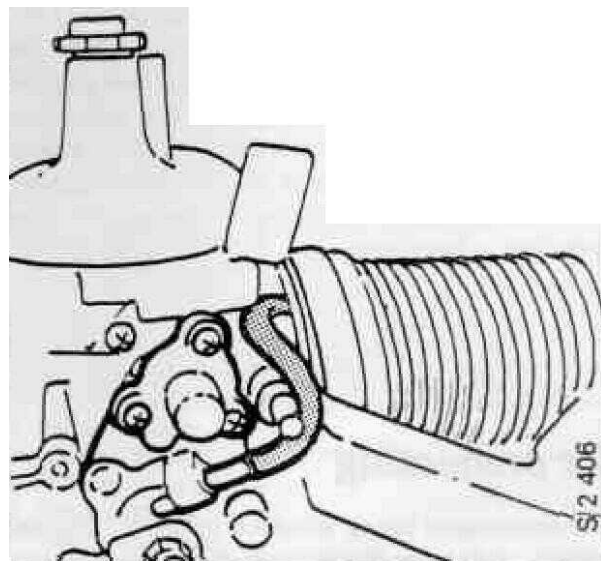

Outlet for EGR valve

In conjunction with the introduction of the EGR system, the carburettor has been equipped with two vacuum outlets. The outlet marked 'E' is connected to the pressure upstream of the throttle butterfly. This outlet is for control of the EGR valve. The other outlet is in communication with the pressure downstream of the throttle butterfly and is connected to the vacuum control unit on the distributor.

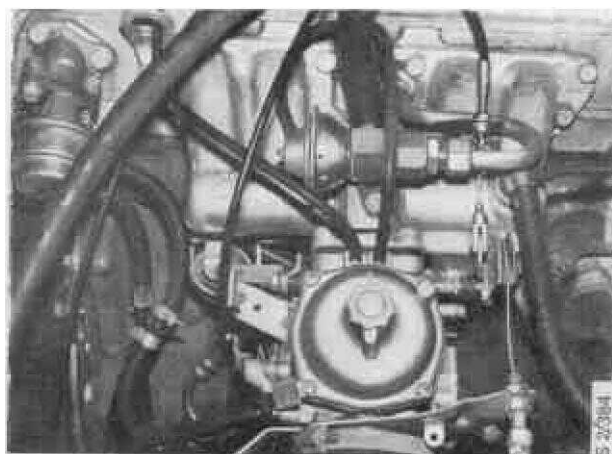

Stromberg

- 1 Outlet for EGR valve
- 2 Vacuum control unit (distributor)

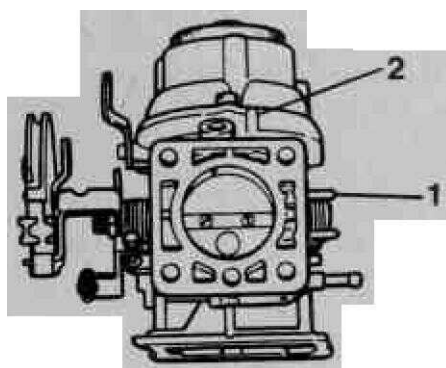

Pierburg

- 1 Outlet for EGR valve
- 2 Vacuum control unit (distributor)

Air cleaner

The air cleaner is positioned at the front of the left wheel housing and is connected to the carburettor by means of a hose. Its purpose is twofold: to clean the air inducted into the engine and to reduce the noise caused by the induction system. The air cleaner element, which is made of a special grade of paper, must not be washed or wetted, but should be replaced at the specified service interval.

Air preheating

A thermostatic valve, situated in the air cleaner intake, regulates the temperature of the induction air.

There are two air intakes in the valve housing: one for cold air and one for heated air. The heated air is drawn in through an insulated hose from a hot spot on the exhaust manifold.

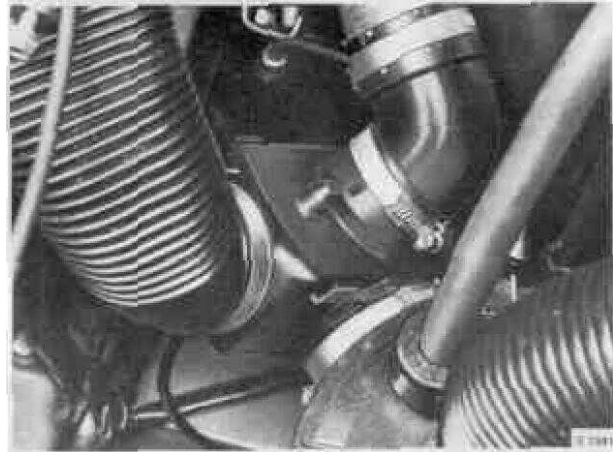

On 1985 and earlier carburettor engines, the valve is activated by a thermostat in front of the carburettor. The thermostat senses the temperature of the pre-mixed induction air and maintains it at 23-37°C (73-98°F) by means of a cable. In operation the valve therefore alternates between the non-preheated and preheated position.

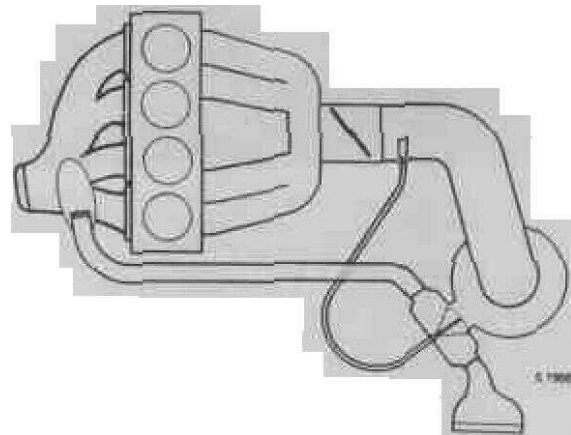

As from 1986 models, the valve butterfly in carburettor engines is controlled not only by a thermostat but also by a bimetallic strip in the air induction hose upstream of the carburettor. The bimetallic strip senses the temperature of the induction air and uses the depression in the inlet manifold to operate the valve butterfly. When the engine is under full load, and the depression in the inlet manifold is weaker, the butterfly is controlled by the thermostat. This system ensures that the induction air to the engine is always at the correct temperature of $25 \pm 5^\circ\text{C}$ ($77 \pm 15^\circ\text{F}$).

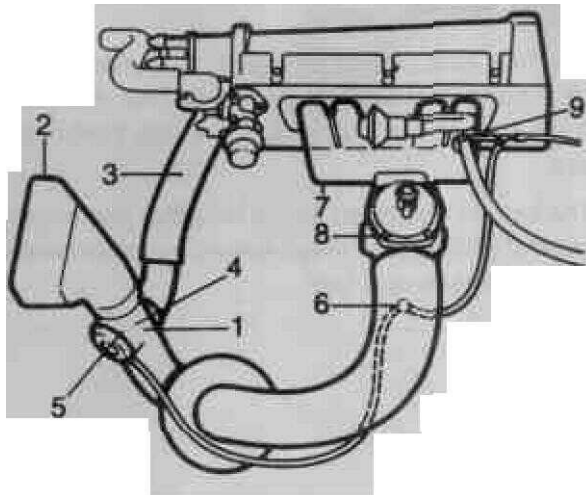

- 1** Valve housing
- 2** Cold-air intake
- 3** Preheated air intake
- 4** Valve butterfly
- 5** Thermostat body
- 6** Bimetallic strip
- 7** Inlet manifold
- 8** Carburettor
- 9** Crankcase ventilation

Fuel pump

The fuel pump is a diaphragm pump, driven by a push-rod from an eccentric on the camshaft. Apart from the filter, which can be removed for cleaning (up to engine No. D 052892), the pump cannot be dismantled for overhaul or repair.

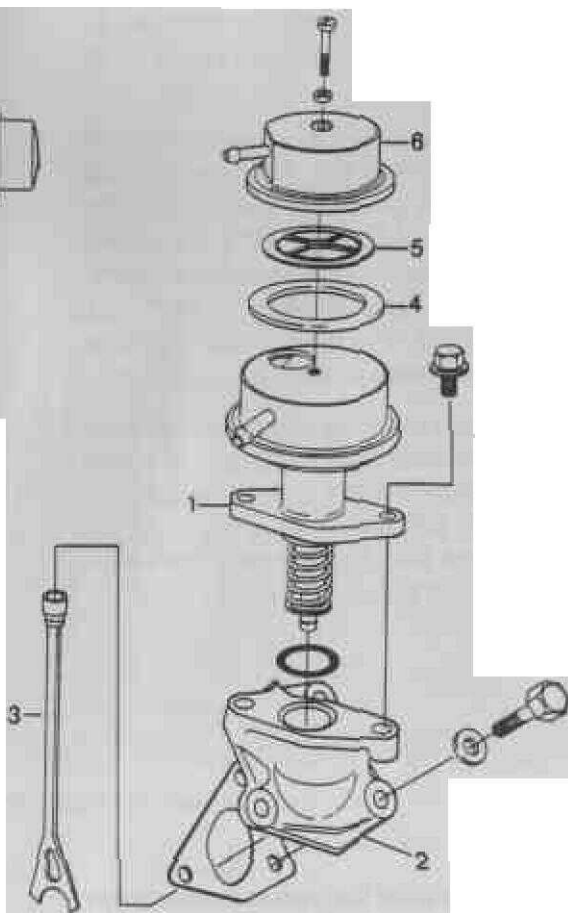
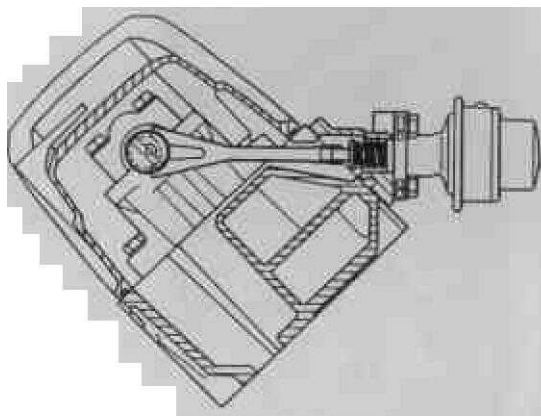

- 1** Fuel pump body
- 2** Adaptor

- 3** Push-rod
- 4** Seal

- 5** Filter
- 6** Cover

Fuel tank

The fuel tank, made of injection-moulded plastic, houses the fuel gauge sender unit, the pump inlet line and a connection for the fuel return line.

The tank is equipped with a breather system and overflow protection, which allows for expansion of the fuel inside the tank.

Fuel tank venting and overflow protection

When fuel is added to the tank air is evacuated partially through breather pipe 3. An air cushion is formed at the top of the tank when the level of fuel reaches the lower opening of the breather pipe (3), owing to the action of a restriction (5) positioned in the breather hose for the upper section of the tank (4). The restriction hinders rapid changes in volume when the car is being refuelled but does not affect gradual changes in volume occasioned by temperature changes or movement of the car.

The tank is vented externally through the vent hose (6) which runs from the filler pipe up the rear corner pillar and along the roof (above the headlining) down through the left front corner pillar and opening into the engine compartment. In cars produced as from the latter half of the 1985 model year, the vent hose is connected to a spigot on the outer end of the filler pipe.

Under normal conditions, the filler cap makes a tight seal with the filler pipe. However, the cap incorporates a vacuum valve which will prevent the fuel tank from collapsing as a result of the pressure difference that could arise if the ventilation system should become blocked.

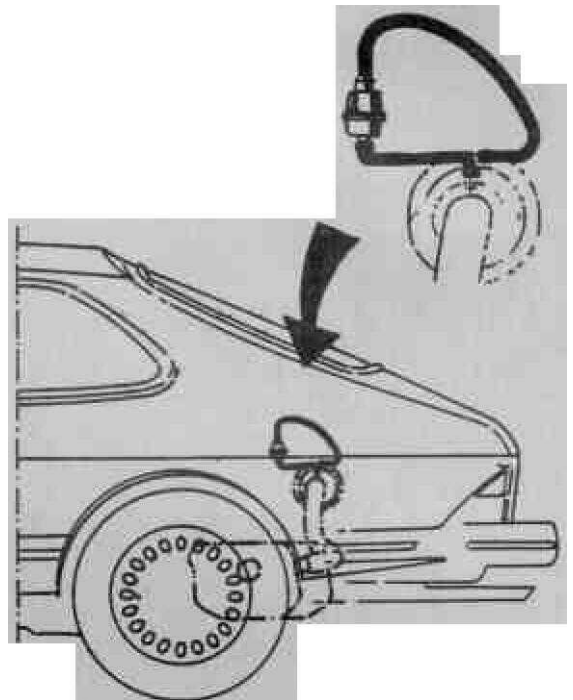

Fuel lines

The fuel system includes both plastic and rubber fuel lines. Plastic pipes are used for runs through the body, and rubber hoses for connections to the fuel tank, fuel pump and carburettor.

The fuel supply and fuel return lines, which run together between the fuel tank and fuel pump, are routed along the rear-seat member and LH side member.

Body **lead-troughs** are sited to the left in the bulkhead panel and to the right in the floor-pan pressing for the rear axle. The lines enter the engine compartment through the LH wheel-arch bracket.

Return fuel

Surplus fuel is returned to the fuel tank via the fuel return line, which is connected to a restriction-type branch connector between the fuel pump and the carburettor. As from 1986 models, the fuel return line is connected to the fuel-return outlet on the vapour trap.

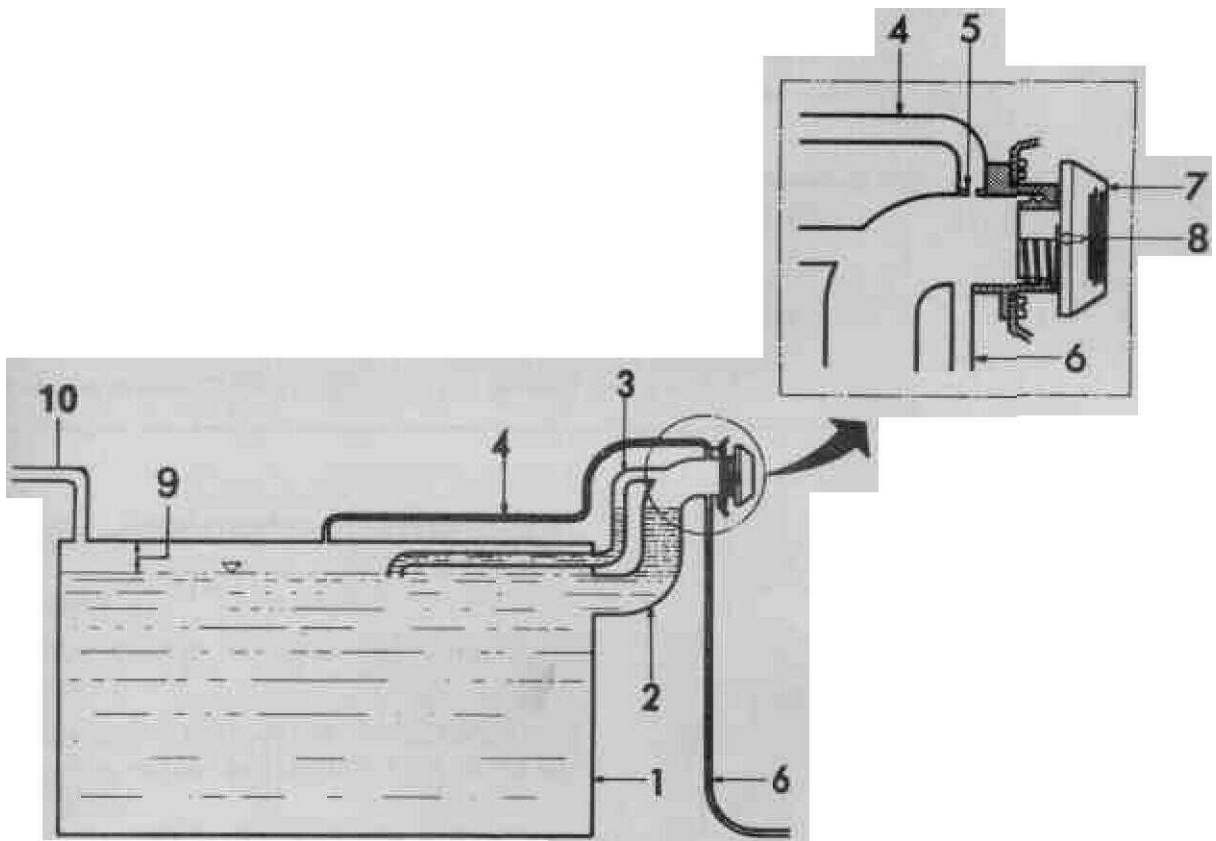

Fuel tank ventilation and breather system

- | | |
|-----------------|---------------------|
| 1 Fuel tank | 6 Vent hose |
| 2 Filler pipe | 7 Filler cap |
| 3 Breather pipe | 8 Vacuum valve |
| 4 Breather hose | 9 Expansion space |
| 5 Restriction | 10 Fuel return line |

Roll-over valve

1984 model cars onwards are equipped with a roll-over valve. The valve is connected to the vent hose for the fuel tank and prevents petrol escaping in the event of the car being involved in a collision.

The valve is located on the right-hand side in the luggage compartment, mounted on the reinforcement panels inside the rear wing.

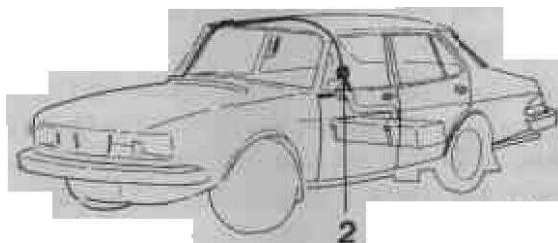

Location of the roll-over valve

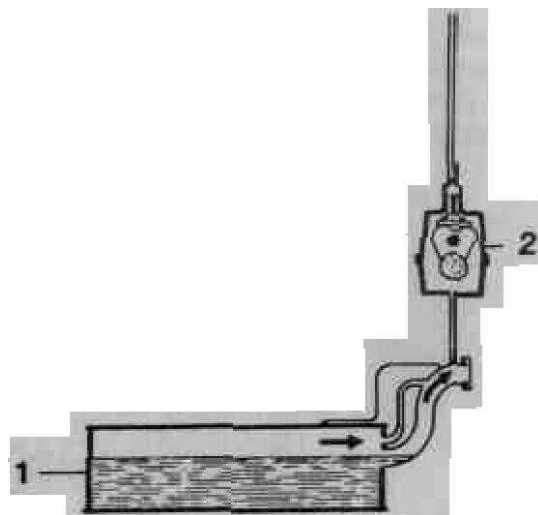

- 1 Fuel tank
- 2 Roll-over valve